

# EXP-20EZ

REVISION: H  
ECO NO.: 2371-4  
BY: M. LLOYD  
DATE: 12/21/06

# COXREELS SERIES EZ-T

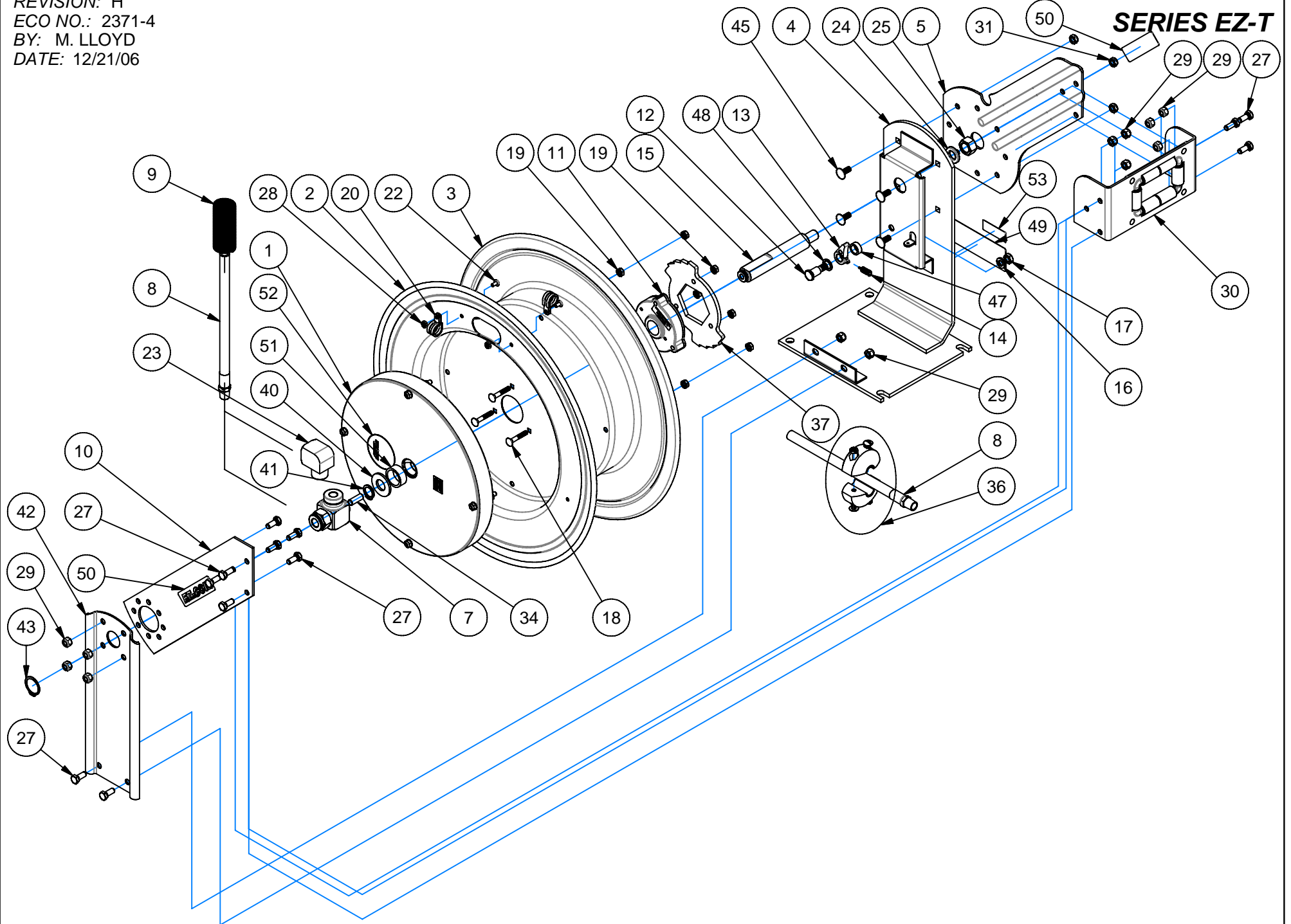

COMMON PARTS TO ALL SERIES EZ-T REELS

ITEM NO.	PART NO.	DESCRIPTION	QTY REQ'D
12	1620	BOLT, SHOULDER, 1/2"x1 1/2"	1
13	640-1-SS	CAM, LOCKING	1
14	274-1-SS	SPRING, DOG	1
15	1794	AXLE	1
16	437	WASHER, LOCK, 3/8"	1
17	184	NUT, JAM, 3/8-16	1
18	1953	BOLT, CARRIAGE, 1/4-20 x 1 1/2" LG. GR 5	3
19	125	NUT, KEPS, 1/4-20	7
22	245	BOLT, 10-32 x 3/8"	2
24	438	WASHER, LOCK, 5/8"	1
25	3584	NUT, 5/8-11	1
27	312	BOLT, 5/16-18 X 3/4"	12
28	130	NUT, KEPS, 10-32	2

ITEM NO.	PART NO.	DESCRIPTION	QTY REQ'D
29	111	NUT, LOCK, 5/16-18	12
31	111-1	NUT, LOCK, 5/16-18 (LOW PROFILE)	4
34	10235-SS	SETSCREW 3/8-16x7/8 CUP PT -SS	1
37	1924	LOCKING RING	1
40	1755-1	WASHER, SPACER	1
41	1753	RETAINING RING (5160-75)	1
45	10220-75	BOLT, CARRIAGE, 5/16"-18 x 3/4"	4
47	6440-SS	WASHER, SPACER	1
48	6441-1	WASHER, SPACER	1
49	10925-5B	LABEL, ID, BLACK	1
50	10950	LABEL, EZ-COIL ARM	2
52	10937	LABEL, EZ-COIL PRODUCT	1
53	10937-1	LABEL, EZ-COIL PATENT NO.	1

ITEM NUMBER

MODEL NO.	1	2	3	4	5	7	8	8	8	9	10	11	20	23	30	36	42	43	51
	SPRING	DRUM	DRUM	BASE	ARM	SWIVEL	HOSE (STD)	HOSE (-OG)	HOSE (-RH)	GUARD	ARM	EZ-COIL	CLAMP (2)	ELBOW	BRKT.	BALL ST	SUPP.	R.RING	SPACER
EZ-TSH-375	698-1	1705	1704	1786	1733	433	5153-75	5101-75	5045-75	237-1	1825	7474-8-R	381	-	1829-1	131-3	1741	1754	7511
EZ-TSH-3100	698-2	1705	1704	1786	1733	433	5153-100	5101-100	5045-100	237-1	1825	7474-8-R	381	-	1829-1	131-3	1741	1754	7511
EZ-TPLL-3100	698-2	1705	1704	1786	1733	433-FG-SS				-	1825	7474-8-R	381	-	1829-1	-	1741	1754	7511
EZ-TSH-450	691-3	1703	1702	1784	1732	434	5154-50	5131-50	5066-50	398-1	1827	7474-6-R	383	-	1829-1	131-4	1740	1754	7511
EZ-TSH-475	692-2	1705	1704	1786	1733	434	5154-75	5131-75	5066-75	398-1	1825	7474-8-R	383	-	1829-1	131-4	1741	1754	-
EZ-TSH-4100	656	1705	1704	1786	1733	434	5154-100	5131-100	5066-100	398-1	1825	7474-8-R	383	-	1829-1	131-4	1741	1754	-
EZ-TSH-535	695-1	1705	1704	1786	1733	426	5155-35	5163-35	5091-35	398-1	1825	7474-8-R	384	385	1829-1	430	1712	516	7511
EZ-TSH-550	692-1	1705	1704	1786	1733	426	5155-50	5163-50	5091-50	398-1	1825	7474-8-R	384	385	1829-1	430	1712	516	-
EZ-TSHF-550	692-1	1705-1	1704	1786	1733	426	5097-50			398-1	1825	7474-8-R	384	385	1829-1	430	1712	516	-

EZ-TMP-350	699-1	1703	1702	1784	1732	433	5224-50			237-1	1827	7474-8-R	381	-	1829-1	131-3	1740	1754	7511
EZ-TMP-375	656	1705	1704	1786	1733	433	5224-75			237-1	1825	7474-10-R	381	-	1829-1	131-3	1741	1754	-
EZ-TMP-450	649	1703	1702	1784	1732	434	5256-50			398-1	1827	7474-10-R	383	-	1829-1	131-4	1740	1754	-
EZ-TMP-475	656	1705	1704	1786	1733	434	5256-75			398-1	1825	7474-10-R	383	-	1829-1	131-4	1741	1754	-
EZ-TMP-550	654	1705	1704	1786	1733	426	5290-50			398-1	1825	7474-10-R	384	385	1829-1	430	1712	516	-

EZ-THP-150	647	1703	1702	1784	1732	499	5304-50			237-1	1827	7474-6-R	115	-	1829-1	131	1740	1754	7511
EZ-THP-175	698-3	1705	1704	1786	1733	499	5304-75			237-1	1825	7474-8-R	115	-	1829-1	131	1741	1754	7511
EZ-THP-1100	657	1705	1704	1786	1733	499	5304-100			237-1	1825	7474-10-R	115	-	1829-1	131	1741	1754	-
EZ-THP-350	696-1	1703	1702	1784	1732	521	5336-50			237-1	1827	7474-8-R	613	-	1829-1	131-3	1740	1754	-
EZ-THP-375	656	1705	1704	1786	1733	521	5336-75			237-1	1825	7474-10-R	613	-	1829-1	131-3	1741	1754	-

EZ-TPHL-3100	657	1705	1704	1786	1733	433-FG-SS				-	1825	7474-10-R	381	-	1829-1	-	1741	1754	-
--------------	-----	------	------	------	------	-----------	--	--	--	---	------	-----------	-----	---	--------	---	------	------	---

\* ON "LESS HOSE" MODELS (EZ-TSHL-/EZ-TMPL-) EXCLUDE ITEMS #8, #9, AND #36.

NOTE: MODELS SUPPLIED WITH "STANDARD" HOSE UNLESS SUFFIXED WITH "-OG" OR "-RH". USE HOSE NUMBERS AS NOTED ABOVE.

REEL ASSEMBLY REPORTS: R100 (LATCHOUT REMOVAL), R101 (LOCKING RING PLACEMENT), R112 (TIGHTENING AND TORQUING)